

SKYJACKER UJI 5036

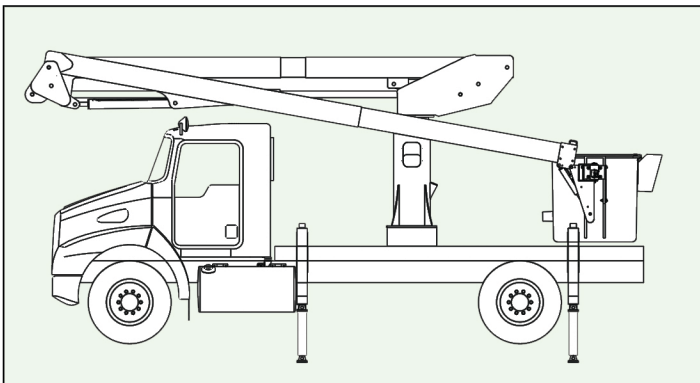

DIMENSIONAL SPECIFICATIONS

Horizontal side reach end mount	36' 2" (11.02m)
Height to bottom of basket	45' 2" (13.75m)
Working height	50' 2" (15.29m)
Stowed height	12 ft 1 in (3.68m)
Upper boom articulation in degrees	-10° to 85°
Lower boom articulation in degrees	0° to 90°
Standard basket capacity	300 lbs (136kg)
Maximum basket capacity	600 lbs (272kg)

MECHANICAL SPECIFICATIONS

- 540° Boom rotation with mechanical stop
- Rotation drive is hourglass worm gear acting on a shear ball bearing
- Side mount basket with hyd. leveling includes upper and lower controls
- All hoses are enclosed within the booms
- Boom elevation by hydraulic cylinders
- Lower boom is high strength steel
- Upper boom is filament wound epoxy resin fiberglass and steel
- Lower boom consists of a parallelogram linkage
- Pedestal is welded structure with reservoir
- Standard color is UTEM white powder coat
- Body harness (Qty 2) with adjustable length shock absorbing lanyard incl.
- Outriggers with boom interlock

RECOMMENDED CHASSIS REQUIREMENTS

Vehicle GVWR	19,500 lbs
Front axle GVWR	7,500 lbs
Rear axle GVWR	14,706 lbs

UJI 5036 meets or exceed ANSI A92.2 and OSHA requirements *

* Based on 40" (1.01m) chassis frame height

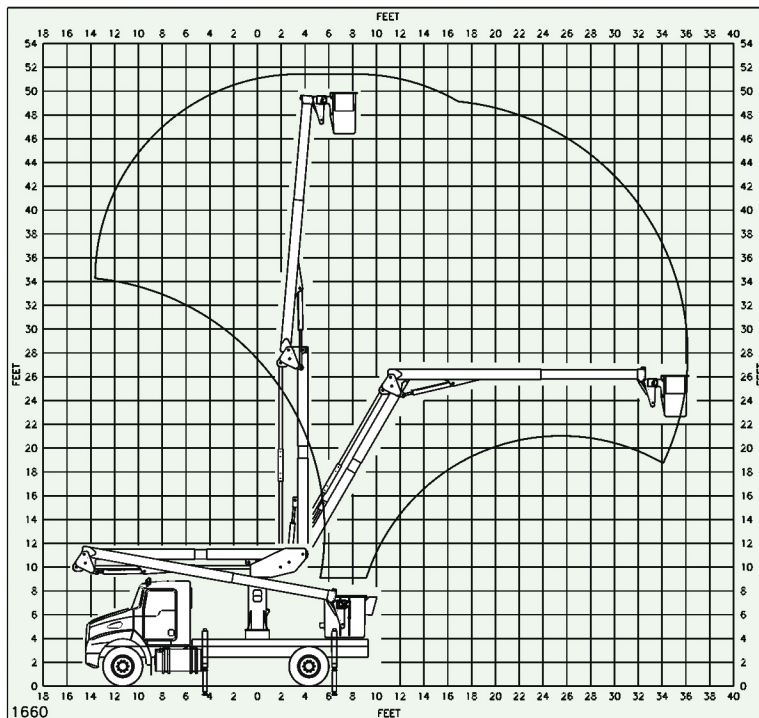

CONTROLS

- Full pressure individual lever locking upper controls
- Turret mounted full pressure lower controls
- Engine stop/start provided with "HM" hydraulics
- Emergency stop is provided at basket controls
- Upper control override is included
- Master switch in chassis cab is provided

HYDRAULIC SPECIFICATIONS

Operating pressure	2,500 PSI
Flow rate	6 GPM
Reservoir capacity w/ sight gauge	15 Gallons (57l)
Suction strainer mounted in reservoir	100 Mesh
Return line filter with bypass	10 Micro

OPTIONAL EQUIPMENT

- Full pressure single stick upper controls
- Continuous rotation
- Fiberglass baskets with steps and doors
- End mount basket
- Hydraulic tool outlet at basket
- 12VDC or 24VDC emergency powered lowering
- Hydraulic basket rotator

1-888-765-3322



Utility Truck Equipment Mfg. L.L.C.
 901 Enterprise Blvd
 Hewitt, Texas 76643
 Phone: 254-857-8204 Fax: 254-857-9253
www.UTEMBuckets.com

THIS DOCUMENT

